

SYSMAC CJ-series Ethernet Unit CJ1W-ETN21

CSM_CJ1W-ETN21_DS_E_3_1

Organically Connect the Production Site and Management

- Select the required communications services according to application needs to flexibly integrate PLCs with an Ethernet information network.



CJ1W-ETN21

Features

- Use Ethernet to implement various communications protocols.
- Implement FINS message communications using UDP/IP or TCP/IP with a user application on a host computer or with Support Software, such as the CX-Programmer.
- Use the clock on an SNTP server to automatically adjust the clocks in the PLCs connected to the Ethernet network. (An SNTP server is required separately.)
- An FTP server is built in, so files can be used to transfer PLC data between network PLCs and workstations or personal computers with an FTP client.
- Email can be used to send commands to the PLCs, or triggers can be set so that the PLCs will send PLC data or Ethernet Unit status to a host computer.
- The standard UDP/IP and TCP/IP protocols are supported to enable communications with a wide range of devices, workstations, personal computers, and Ethernet modules from other manufacturers.
- The SMTP/POP3/SNTP servers enable the use of host names instead of IP addresses. (A DNS server is required separately.)

System Configuration

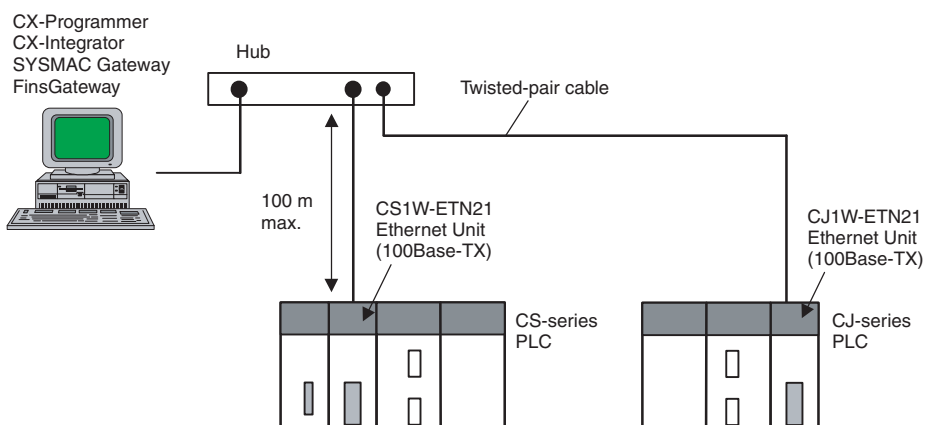

Ordering Information

• International Standards

- The standards are abbreviated as follows: U: UL, U1: UL (Class I Division 2 Products for Hazardous Locations), C: CSA, UC: cULus, UC1: cULus (Class I Division 2 Products for Hazardous Locations), CU: cUL, N: NK, L: Lloyd, and CE: EC Directives.
- Contact your OMRON representative for further details and applicable conditions for these standards.



Ethernet Unit

Unit type	Product name	Specifications			No. of unit numbers allocated	Current consumption (A)		Model	Standards
		Communications cable	Communications functions	Units per CPU Unit		5 V	24 V		
CJ1 CPU Bus Unit	 Ethernet Unit	100Base-TX	FINS communications service (TCP/IP, UDP/IP), FTP server functions, socket services, mail transmission service, mail reception (remote command receive), automatic adjustment of PLC's built-in clock, server/host name specifications	4 *	1	0.37	–	CJ1W-ETN21	UC1, N, L, CE

* Up to three Ethernet Units can be connected to a CJ1M-CPU1□-ETN CPU Unit.

Note: There is no accessory for the CJ-series Ethernet Unit.

Industrial Switching Hubs

Product name	Appearance	Specifications			Accessories	Current consumption (A)	Model	Standards
		Functions	No. of ports	Failure detection				
Industrial Switching Hubs		Quality of Service (QoS): EtherNet/IP control data priority Failure detection: Broadcast storm and LSI error detection 10/100BASE-TX, Auto-Negotiation	3	No	<ul style="list-style-type: none"> • Power supply connector 	0.22	W4S1-03B	UC, CE
	5		No	0.22		W4S1-05B		
			5	Yes	<ul style="list-style-type: none"> • Power supply connector • Connector for informing error 	0.22	W4S1-05C	CE

Recommended Network Devices

The following products are recommended for use with the Ethernet Unit.

Part	Maker	Model number	Specifications
Hub	100BASE-TX		
	PHOENIX CONTACT	SWITCH 5TX	10/100 Mbit/s 5-port hub
Twisted-pair cable	100BASE-TX		
	Fujikura	F-LINK-E 0.5mm × 4P	STP (shielded twisted-pair) cable: Category 5, 5e Note: Impedance is limited to 100 Ω.
	Fujikura	CTP-LAN5 0.5mm × 4P	UTP (unshielded twisted-pair) cable: Category 5, 5e
	10BASE-T		
	Fujikura	F-LINK-E 0.5mm × 4P	STP (shielded twisted-pair) cable: Category 3, 4, 5, 5e Note: Impedance is limited to 100 Ω.
Connectors (Modular plug)	STP Plug		
	Panduit Corp	MPS588	–
	UTP Plug		
	Panduit Corp	MP588-C	–

Mountable Racks

Model	CJ System (CJ1, CJ2)		CP1H System	NSJ System	
	CPU Rack	Expansion Backplane	CP1H PLC	NSJ Controller	Expansion Backplane
CJ1W-ETN21	4 Units (per CPU Unit) *1		2 Units *2	Not supported	4 Units *3

*1. Up to three Ethernet Units can be connected to a CJ1M-CPU1□-ETN CPU Unit.

*2. A CP1W-EXT01 CJ Unit Adaptor is required.

*3. If an Expansion Rack is used, the NSJW-CLK21-V1 or NSJW-ETN21 cannot be mounted to the NSJ Controller.

Ethernet Units Specifications

Item	Specifications		
Model number	CJ1W-ETN21		
Type	100Base-TX (Can be used as 10Base-T)		
Applicable PLCs	CJ-series PLCs		
Unit classification	CJ-series CPU Bus Unit		
Mounting location	CPU Rack or Expansion Rack		
Number of Units that can be mounted	4 max. (including Expansion Racks)		
Transfer specifications	Media access method	CSMA/CD	
	Modulation method	Baseband	
	Transmission paths	Star form	
	Baud rate	100 Mbit/s (100Base-TX)	10 Mbit/s (10Base-TX)
	Transmission media	Unshielded twisted-pair (UDP) cable Categories: 5, 5e Shielded twisted-pair (STP) cable Categories: 100 Ω at 5, 5e	Unshielded twisted-pair (UDP) cable Categories: 3, 4, 5, 5e Shielded twisted-pair (STP) cable Categories: 100 Ω at 3, 4, 5, 5e
	Transmission distance	100 m (distance between hub and node)	
Number of cascade connections	No restrictions if switching hubs are used.		
Current consumption (Unit)	370 mA max. at 5 V DC		
Weight	100 g max.		
Dimensions	31 × 90 × 65 mm (W × H × D)		
Other general specifications	Other specifications conform to the general specifications of the CJ-series.		

Communications Specifications

Item	Ethernet Unit	
Model number	CJ1W-ETN21	
Physical layer	100BASE-TX, 10BASE-T	
Number of nodes on FINS network	254	
Server specification	Specification by IP address or host name specifications (DNS client function)	
Communications service	FINS communications service	FINS/UDP FINS/TCP
	FTP server function	The CPU Unit's file memory (Memory Card or EM file memory) can be read/written.
	Automatic clock information adjustment	The CPU Unit's internal clock data can be automatically adjusted to the clock data received from the SNTP server
	Web functions	The Unit settings can be made and status can be read from the Web browser using the Web server.
	Mail functions	Mail send functions Mail receive functions
	Socket service function	TCP socket services UDP socket services
	FINS commands	RESET
		CONTROLLER DATA READ
		CONTROLLER STATUS READ
		ECHOBACK TEST
		BROADCAST TEST (READ RESULTS)
		BROADCAST TEST (SEND TEST DATA)
		ERROR LOG READ
		ERROR LOG CLEAR
		REQUEST TO OPEN UDP SOCKET
		REQUEST TO RECEIVE UDP SOCKET
		REQUEST TO SEND UDP SOCKET
		REQUEST TO CLOSE UDP SOCKET
		REQUEST TO OPEN TCP SOCKET (PASSIVE)
		REQUEST TO OPEN TCP SOCKET (ACTIVE)
		REQUEST TO RECEIVE TCP SOCKET
		REQUEST TO SEND TCP SOCKET
		REQUEST TO CLOSE TCP SOCKET
		EXECUTE PING COMMAND
		REQUEST TO CHANGE REMOTE NODE FOR FINS/TCP CONNECTION
		REQUEST TO READ STATUS FOR FINS/TCP CONNECTION
	IP ADDRESS TABLE WRITE	
IP ADDRESS WRITE		
IP ADDRESS TABLE READ		
IP ROUTING TABLE READ		
PROTOCOL STATUS READ		
MEMORY STATUS READ		
SOCKET STATUS READ		
ADDRESS DATA READ		
IP ADDRESS READ		

External Interface

CJ1W-ETN21

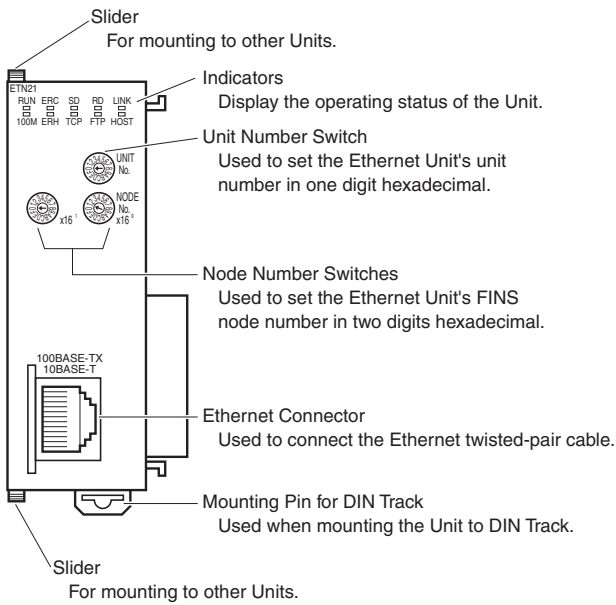

Each communications device connected to the Ethernet network is allocated a unique Ethernet address. For the Ethernet Unit, this Ethernet address is shown on the right side of the Unit as a 12-digit hexadecimal number.

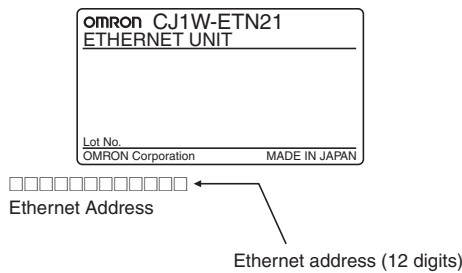

Ethernet Connectors

The following standards and specifications apply to the connectors for the Ethernet twisted-pair cable.

- Electrical specifications: Conforming to IEEE802.3 standards.
- Connector structure: RJ45 8-pin Modular Connector (conforming to ISO 8877)

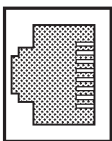

Connector pin	Signal name	Abbr.	Signal direction
1	Transmission data +	TD+	Output
2	Transmission data -	TD-	Output
3	Reception data +	RD+	Input
4	Not used.	-	-
5	Not used.	-	-
6	Reception data -	RD-	Input
7	Not used.	-	-
8	Not used.	-	-
Hood	Frame ground	FG	-

Unit Version Upgrade Information

Unit Version 1.3

Upgrade	Details
Web function added	The unit settings and status monitoring for the Ethernet Unit can be easily performed from a Web browser.
Function prohibiting access using FINS/UDP from nodes with dynamically changed IP addresses	Access to change the remote IP address from a node using FINS/UDP can be prohibited (IP address protection).

Unit Version 1.4

Upgrade	Details
ETN11-compatible mode added to the ETN21 settings for FINS/UDP.	A mode compatible with the CS1W-ETN11/CJ1W-ETN11 was added in the operating specifications for FINS/UDP messages sent from a different UDP port number than the FINS/UDP port number set in the Ethernet Unit.

Unit Version 1.5

Upgrade	Details
CIDR function added to subnet mask settings	An option setting was added to the subnet mask settings to enable CIDR. Enabling CIDR allows you to use classless IP addresses in the subnet mask setting.
High-speed option added for socket service	This option can be set to improve communications performance for the socket service that is implemented by manipulating dedicated control bits. The performance is the same as the previous version if this option is not set.
Linger option added to socket options for TCP open requests.	A linger option can now be set in the options for passive or active TCP open requests.
Location of node address switches changed on CJ1W-ETN21	The location of the node address switches was changed. The setting method and setting range remain the same.

Note: CX-Programmer version 8.2 or higher is required for unit version 1.5 functions.

Dimensions

(Unit: mm)

CJ1W-ETN21

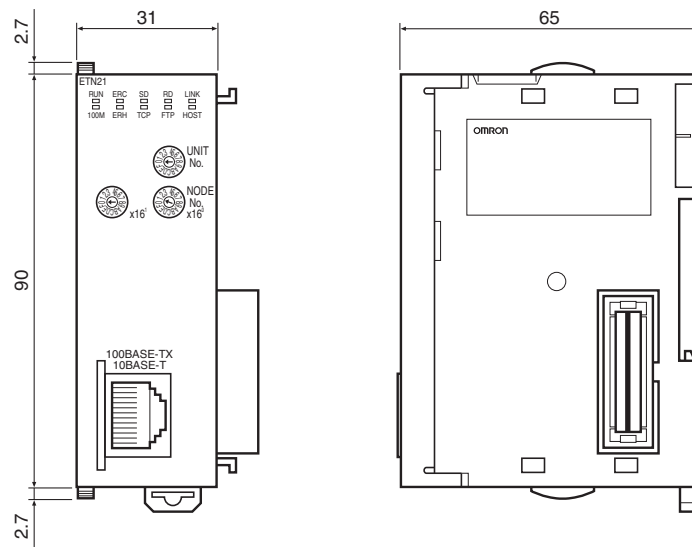

Related Manuals

Man.No.	Model	Name	Contents
W420	CS1W-ETN21 CJ1W-ETN21	Ethernet Units Operation Manual Construction of Networks	Provides information on operating and installing 100Base-TX Ethernet Units, including details on basic settings and FINS communications. Refer to the Communications Commands Reference Manual (W342) for details on FINS commands that can be sent to CS-series and CJ-series CPU Units when using the FINS communications service.
W421	CS1W-ETN21 CJ1W-ETN21	Ethernet Units Operation Manual Construction of Applications	Provides information on constructing host applications for 100Base-TX Ethernet Units, including functions for sending/receiving mail, socket service, automatic clock adjustment, FTP server functions, and FINS communications.
W342	CS1G/H-CPU□□H CS1G/H-CPU-□□EV1 CS1D-CPU□□H CS1D-CPU□□S CJ1M-CPU□□ CS1W-SCU21-V1 CS1W-SCB21-V1/41-V1 CJ1G/H-CPU□□H CJ1G-CPU□□P CJ1G-CPU□□ CJ1W-SCU21-V1/41-V1	Communications Commands Reference Manual	Describes the C-series (Host Link) and FINS communications commands used when sending communications commands to CS-series and CJ-series CPU Units.
W463	CXONE-AL□□C-V□/ AL□□D-V□	CX-One Setup Manual	Describes operating procedures for the CX-One FA Integrated Tool Package. Refer to this manual for operating procedures for the CX-One FA Integrated Tool Package.
W464	CXONE-AL□□C-V□/ CXONE-AL□□D-V□	CS/CJ/CP/NSJ-series CX-Integrator Network Configuration Software Operation Manual	Describes the operating procedures for the CX-Integrator.

Read and Understand This Catalog

Please read and understand this catalog before purchasing the products. Please consult your OMRON representative if you have any questions or comments.

Warranty and Limitations of Liability

WARRANTY

OMRON's exclusive warranty is that the products are free from defects in materials and workmanship for a period of one year (or other period if specified) from date of sale by OMRON.

OMRON MAKES NO WARRANTY OR REPRESENTATION, EXPRESS OR IMPLIED, REGARDING NON-INFRINGEMENT, MERCHANTABILITY, OR FITNESS FOR PARTICULAR PURPOSE OF THE PRODUCTS. ANY BUYER OR USER ACKNOWLEDGES THAT THE BUYER OR USER ALONE HAS DETERMINED THAT THE PRODUCTS WILL SUITABLY MEET THE REQUIREMENTS OF THEIR INTENDED USE. OMRON DISCLAIMS ALL OTHER WARRANTIES, EXPRESS OR IMPLIED.

LIMITATIONS OF LIABILITY

OMRON SHALL NOT BE RESPONSIBLE FOR SPECIAL, INDIRECT, OR CONSEQUENTIAL DAMAGES, LOSS OF PROFITS OR COMMERCIAL LOSS IN ANY WAY CONNECTED WITH THE PRODUCTS, WHETHER SUCH CLAIM IS BASED ON CONTRACT, WARRANTY, NEGLIGENCE, OR STRICT LIABILITY.

In no event shall the responsibility of OMRON for any act exceed the individual price of the product on which liability is asserted.

IN NO EVENT SHALL OMRON BE RESPONSIBLE FOR WARRANTY, REPAIR, OR OTHER CLAIMS REGARDING THE PRODUCTS UNLESS OMRON'S ANALYSIS CONFIRMS THAT THE PRODUCTS WERE PROPERLY HANDLED, STORED, INSTALLED, AND MAINTAINED AND NOT SUBJECT TO CONTAMINATION, ABUSE, MISUSE, OR INAPPROPRIATE MODIFICATION OR REPAIR.

Application Considerations

SUITABILITY FOR USE

OMRON shall not be responsible for conformity with any standards, codes, or regulations that apply to the combination of products in the customer's application or use of the products.

At the customer's request, OMRON will provide applicable third party certification documents identifying ratings and limitations of use that apply to the products. This information by itself is not sufficient for a complete determination of the suitability of the products in combination with the end product, machine, system, or other application or use.

The following are some examples of applications for which particular attention must be given. This is not intended to be an exhaustive list of all possible uses of the products, nor is it intended to imply that the uses listed may be suitable for the products:

- Outdoor use, uses involving potential chemical contamination or electrical interference, or conditions or uses not described in this catalog.
- Nuclear energy control systems, combustion systems, railroad systems, aviation systems, medical equipment, amusement machines, vehicles, safety equipment, and installations subject to separate industry or government regulations.
- Systems, machines, and equipment that could present a risk to life or property.

Please know and observe all prohibitions of use applicable to the products.

NEVER USE THE PRODUCTS FOR AN APPLICATION INVOLVING SERIOUS RISK TO LIFE OR PROPERTY WITHOUT ENSURING THAT THE SYSTEM AS A WHOLE HAS BEEN DESIGNED TO ADDRESS THE RISKS, AND THAT THE OMRON PRODUCTS ARE PROPERLY RATED AND INSTALLED FOR THE INTENDED USE WITHIN THE OVERALL EQUIPMENT OR SYSTEM.

PROGRAMMABLE PRODUCTS

OMRON shall not be responsible for the user's programming of a programmable product, or any consequence thereof.

Disclaimers

CHANGE IN SPECIFICATIONS

Product specifications and accessories may be changed at any time based on improvements and other reasons.

It is our practice to change model numbers when published ratings or features are changed, or when significant construction changes are made. However, some specifications of the products may be changed without any notice. When in doubt, special model numbers may be assigned to fix or establish key specifications for your application on your request. Please consult with your OMRON representative at any time to confirm actual specifications of purchased products.

DIMENSIONS AND WEIGHTS

Dimensions and weights are nominal and are not to be used for manufacturing purposes, even when tolerances are shown.

PERFORMANCE DATA

Performance data given in this catalog is provided as a guide for the user in determining suitability and does not constitute a warranty. It may represent the result of OMRON's test conditions, and the users must correlate it to actual application requirements. Actual performance is subject to the OMRON Warranty and Limitations of Liability.

ERRORS AND OMISSIONS

The information in this document has been carefully checked and is believed to be accurate; however, no responsibility is assumed for clerical, typographical, or proofreading errors, or omissions.

2009.11

In the interest of product improvement, specifications are subject to change without notice.

OMRON Corporation
Industrial Automation Company

<http://www.ia.omron.com/>

(c)Copyright OMRON Corporation 2009 All Right Reserved.